



# CENTER OF TECHNOLOGICAL INITIATIVES, LLC

info@cti-sumy.com.ua

Предлагаем услуги по сервисному обслуживанию и поставке оборудования Shenzhen GuanHong Automation (SZGH).

В рамках ремонта мы выполним осмотр и диагностику неисправностей, техническое обслуживание и замену повреждённых элементов, а также консультацию по установке и эксплуатации.

У нас большой опыт в работе с оборудованием SZGH. Мы часто используем его при изготовлении собственных машин

## Контакты:

 <http://cti-sumy.com.ua>

 [info@cti-sumy.com.ua](mailto:info@cti-sumy.com.ua)

[sales1@cti-sumy.com.ua](mailto:sales1@cti-sumy.com.ua)

 <https://www.facebook.com/cti.sumy>

 <https://www.youtube.com/channel/UCyYGmKVZ2FwZnoX4RV8ls0g>

## Машины под индивидуальные требования



**Сварочный станок**



**Сварочный станок**



**Сварочный станок**



**Сварочный  
полуавтоматический  
станок**



**Сварочный станок**

# **User Manual**

## **Servo driver SZGH-302**

**(one driver to control two motors simultaneously)**

Shenzhen Guanhong Automation CO.,LTD

Website: [www.szghauto.com](http://www.szghauto.com)

Add:Room 503 Anxin Building, No 536 Shenhui Road, Liuyue community, Henggang Street ,Longgang District, Shenzhen City,Guangdong Province, ChinaProvince, China

Post code: 518115



# Chapter 1 System's Installation and Connection

## 1.1 System's Installation

### 1.1.1 System's Technical Parameter

- Mode of control: position、velocity and JOG control
- Mode of input: pulse signal or analog voltage(0~±10V)
- Frequency of pulse: <500KHz
- Electronic gear: 1/30000~30000
- Precision of control: ±0.01%

### 1.1.2 Conditions of System's Installation

- Input Power: single-phase or three-phase : ~220V (+10%, -15%), frequency :50Hz±1Hz
- Runing Temperature: 0~55℃, relative humidity: 40-80%
- Storing or Transporting Temperature: -10~70℃, relative humidity:<=90%
- Vibration: <0.5G,10~60Hz
- Atmosphere pressure: 86-106kpa
- No excessive flour dust、acid、alkali caustic gas and explosive gas, no strong electromagnetic interference
- Direction of installation: servo drive's installation direction must be upright
- The ambient should be well ventilated

### 1.1.3 Installation dimension figure (255x105x199)

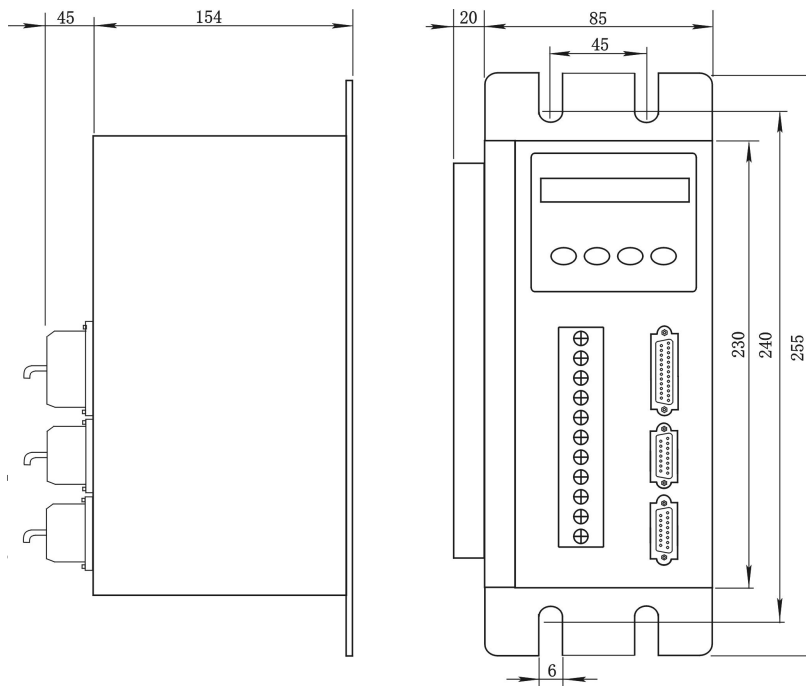

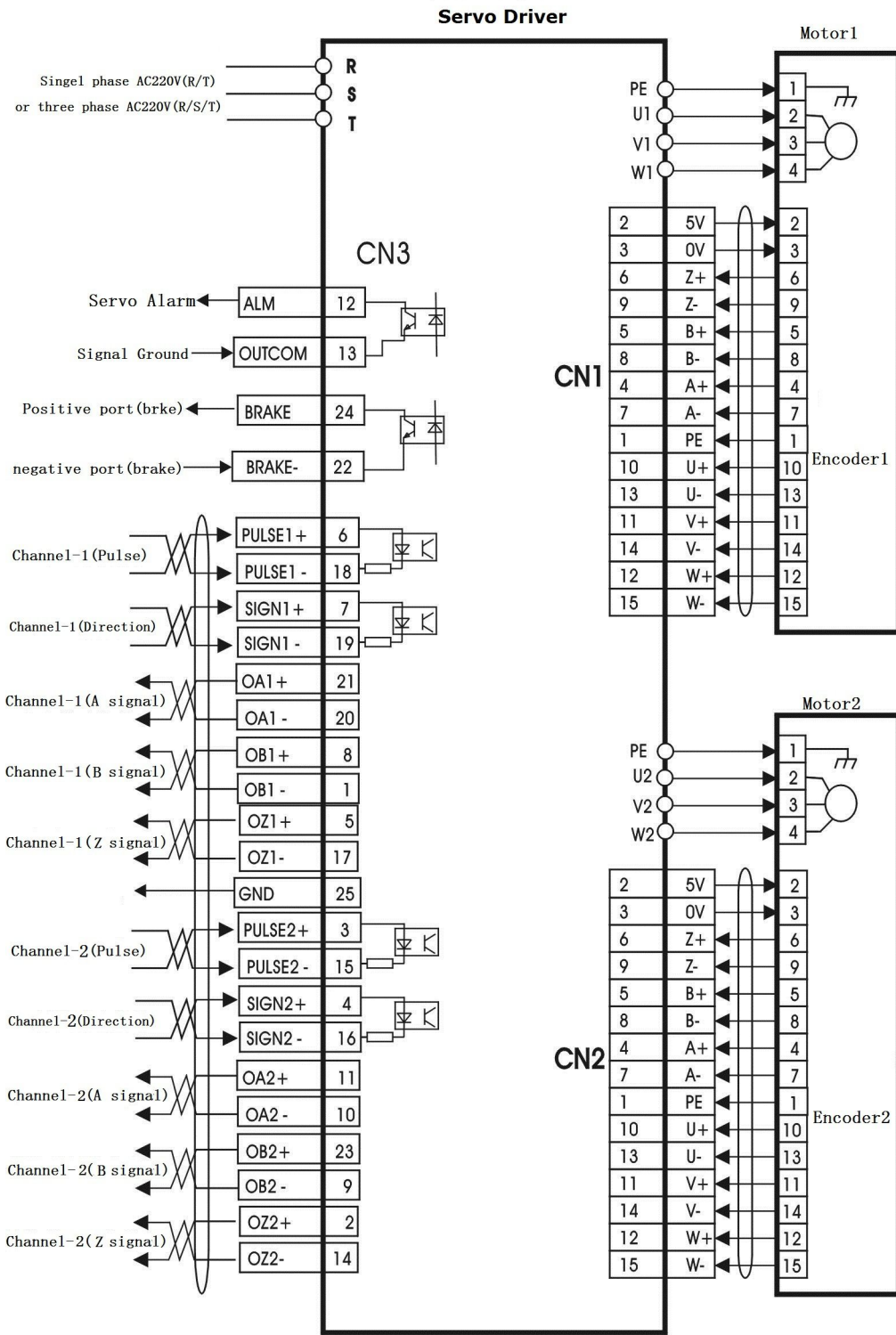

Standard Wiring Diagram

## 1.2.2 Control signal's attribute

### 1.2.2.1 Power input interface (11 pin)

Pin	Sign	Signal name	Signal function
1	R	Single-phase or three-phase AC220V	Servo power
2	S		
3	T		
4	PE	Earthing	Earthing terminal
5	U1	Servo motor's output	Connect with motor's U1、V1、W1
6	V1		
7	W1		
8	PE	Earthing	Connect with the shell of motor
9	U2	Servo motor's output	Connect with motor's U2、V2、W2
10	V2		
11	W2		

### 1.2.2.2 In/out control signal interface (CN3 25pin)

Pin	Sign	Signal name	I/O method	Signal Explanation
12	ALM	Servo alarm positive terminal	Output	When alarm output is on, forbid servo
13	Out-COM	0v	Input	0V
24	BRAKE+	Positive port (brake)	Output	
22	BRAKE-	Negative port(brake)	Input	
6	CP1+	Pulse signal positive terminal	Input	Channel-1 External position order pulse+direction
18	CP1-	Pulse signal negative terminal	Input	
7	DIR1+	Direction signal positive terminal	Input	
19	DIR1-	Direction signal negative terminal	Input	
5	OZ1+	Encoder Z+	output	Z pulse positive pin
17	OZ1-	Encoder Z-	output	Z pulse negative pin
8	OB1+	Encoder B+	output	B pulse positive pin
1	OB1-	Encoder B-	output	B pulse negative pin
21	OA1+	Encoder A+	output	A pulse positive pin
20	OA1-	Encoder A-	output	A pulse negative pin
25	GND	Signal ground	output	

3	CP2+	Pulse signal positive terminal	Input	Channel-2 External position order pulse+direction
15	CP2-	Pulse signal negative terminal	Input	
4	DIR2+	Direction signal positive terminal	Input	
16	DIR2-	Direction signal negative terminal	Input	
11	OZ2+	Encoder Z+	output	Z pulse positive pin
10	OZ2-	Encoder Z-	output	Z pulse negative pin
23	OB2+	Encoder B+	output	B pulse positive pin
9	OB2-	Encoder B-	output	B pulse negative pin
2	OA2+	Encoder A+	output	A pulse positive pin
14	OA2-	Encoder A-	output	A pulse negative pin

1.2.2.3 Encoder input signal (CN1&CN2 15pin) , encoder output pulse

Pin	Sign	Signal name	I/O method	Signal Explain
2	VCC	Power +5V	Output	Encoder power
3	GND	Signal ground	Output	
6	Z+	Encoder Z+	Input	Z pulse positive pin
9	Z-	Encoder Z-	Input	Z pulse negative pin
5	B+	Encoder B+	Input	B pulse positive pin
8	B-	Encoder B-	Input	B pulse negative pin
4	A+	Encoder A+	Input	A pulse positive pin
7	A-	Encoder A-	Input	A pulse negative pin
1	PE	Earthing terminal	Input	System earthing
10	U+	Encoder U+	Input	U pulse positive pin
13	U-	Encoder U-	Input	U pulse negative pin
11	V+	Encoder V+	Input	V pulse positive pin
14	V-	Encoder V-	Input	V pulse negative pin
12	W+	Encoder W+	Input	W pulse positive pin
15	W-	Encoder W-	Input	W pulse negative pin

## 1.3 In/out interface principle

### 1.3.1 Output signal interface of ALM (same as SRDY)

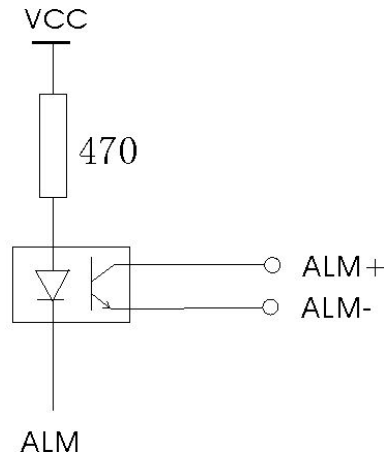

When servo System gives an alarm to show an error, besides LED displays error P, the output of ALM is available. The output is open collector mode, the maximum output current is 200mA.

SRDY is servo ready signal, as available, exterior controller inputs control order to servo System. the maximum output current is 20mA.

### 1.3.2 Pulse input signal interface

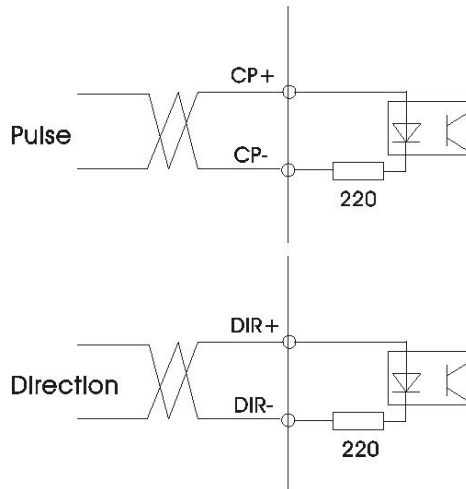

Signal input should adopt difference drive mode. When adopting single drive mode, power must be 10~15mA/5V, power need SZGH-resistance to limit the current as over 5V. The input signal line should be shielded twisted-pair in order to reduce interference.

Pulse input mode:

Pulse mode	CW		Pa.14
	CCW	PULS	
Pulse+ Direction	PULS		0
	SIGN		



CCW+CW	PULS		1
	SIGN		
A+B 90°	PULS		2
	SIGN		

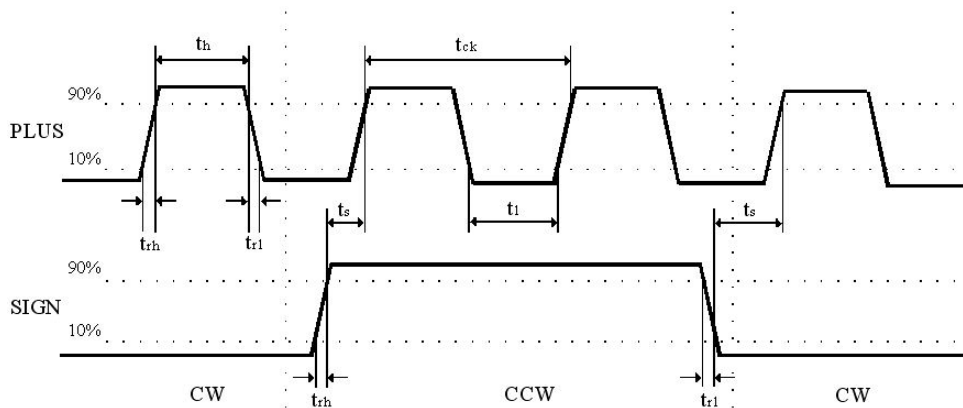

Pulse+ Direction (frequency<500kHz)

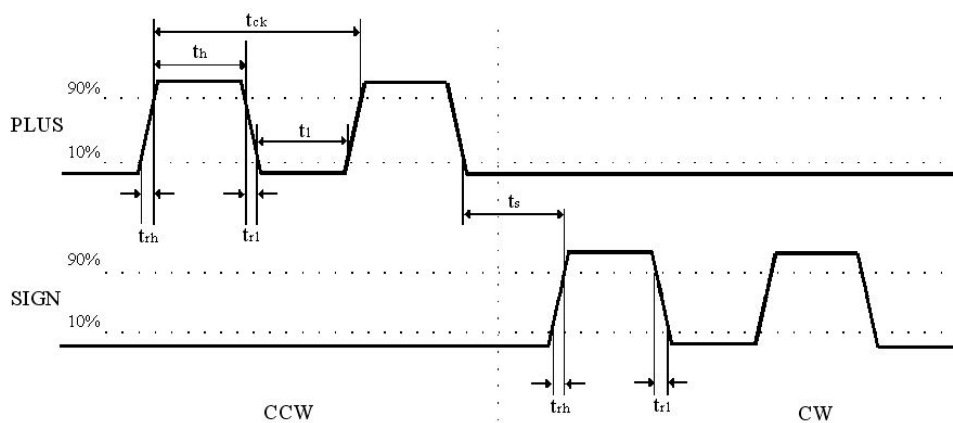

CW+CCW (frequency<500kHz)

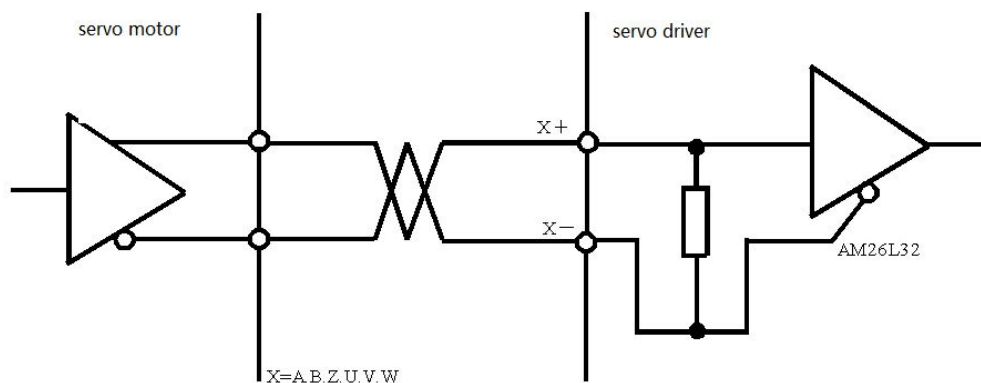

Motor encode signal

### Pulse input wave map

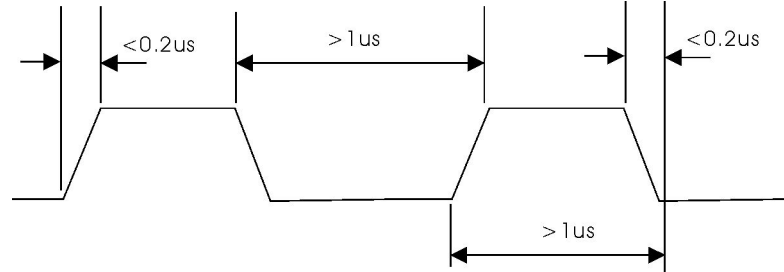

### 1.3.3 Encoder output signal interface

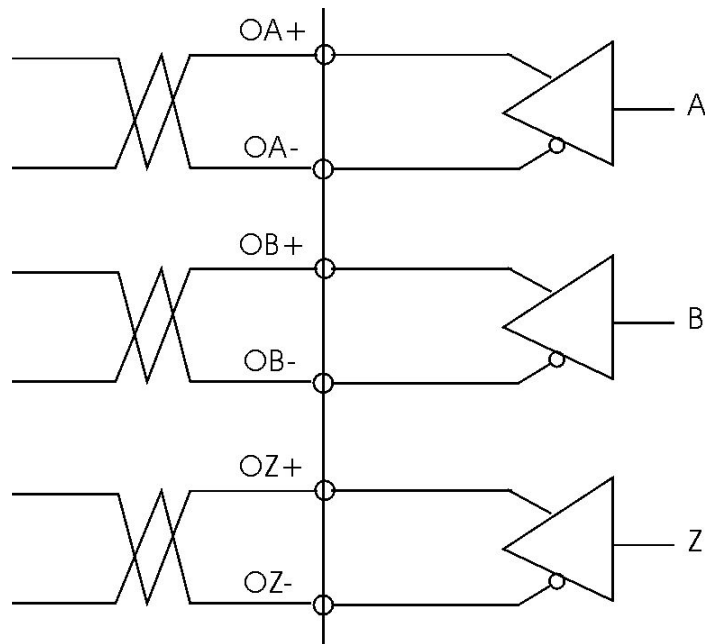

Output signal uses difference driver AM26LS31, also named long line drive output. The output signal line should be shielded twisted-pair in order to reduce interference.

## Chapter 2 Servo System's parameter function

### 2.1 Parameter table

(note:for example,Pa.3,when a=0,P0.3 means the 3rd parameter of driver,when a=1,P1.3 means the 3rd parameter of Channel-1 driver,when a=2,P2.3 means the 3rd parameter of Channel-2 driver.)

P	Paramter name	Paranter function	Paranter range	Factory value
P0.1	Password	Guard against mistaken or ill-purposed change of parameter It is invalidation If it is 9999	1~9999	1
P0.2	Display channel	1: display channel-1 2: display channel-2	1~2	1
P0.3	First display status	0 : Display motor rotating speed (r/min) 1 : Display motor current (A) 2 : Display motor torque (NM) 3: Display motor position (0~9999) 4: Display count difference 5: Display low four bits of pluse count (pulse) 6: Display high four bits of pluse count(x1000pulse) 7: Display straight line speed(m/min) 8 : Display input frequency(kHz) 9: Display input status 10: Display output status 11: Display Error NO. 12: No Display	0~12	0
P0.4	Driver's type	User cannot change		
P0.5	Servo soft version	User cannot change		

P0.6	Set SRV-ON disable	0: Enable 1: Disable, won't examine SRV-ON input signal	0~1	1
Pa.7	Select control mode a=1,it is channel-1; a=2,it is channel-2	0: Position control mode 1: JOG control mode 2: Speed control mode 3: Power control mode 4: Position and speed control mode (channel-1 EN select, channel-2 INTH select) 5: inner pulse control inner startup	0~5	0
Pa.8	Current proportion gain	① As this is bigger, response is more rapid, and easy to produce vibration ② Commonly set to be zero except very high response frequency is needed	1~600	430
Pa.9	Speed proportion gain	① The bigger gain is, the higher the rigidity is. ② The smaller load is, the smaller set value ③ Should set bigger parameter value under the condition of no vibration and noise	1~400	80
Pa.10	Forward feedback gain	As this is bigger, response is more rapid, and easy to produce vibration	1~400	100
Pa.11	Speed and proportion gain	① As this is less motor will run more stably, but rigidity will become bad ② As this is bigger, position control's orientation will be more rapidly	1~8000	100
Pa.12	Position order pulse numerator 1	① Motor's pulse number per rotate =10000x numerator / denominator	1~30000	1
Pa.13	Position order pulse denominator	② Electronic gear $G = \text{numerator} / \text{denominator}$ $1/30000 < G < 30000$	1~30000	1

Pa.14	Pulse mode	0: Pulse+Sign 1: CW+CCW 2: A+B 90°	0~2	0
Pa.15	Reverse Position order direction	0: No change 1: Reverse	0~1	0
Pa.16	Reverse speed order direction	0: No change 1: Reverse	0~1	0
Pa.17	Orientation finish range	As difference count isn't larger than this value , orientation will be complete	0~30000	2
Pa.18	Range of checking position error	As difference count is larger than this value , alarm of positioning will produce	0~30000	30000
Pa.19	Position error is disable	0: Enable 1: Disable	0~1	0
Pa.20	Position pulse channel Setting	0: oneself channel 1: other channel	0~1	0
Pa.21	Jog speed channel	1:Pa.23 2:Pa.24 3:Pa.25 4:Pa.26	1~4	1
Pa.22	Speed control speed channel	1:Pa.23 2:Pa.24 3:Pa.25 4:Pa.26	1~4	1
Pa.23	Interior speed 1	For JOG and speed mode	0~±6000 r/min	10
Pa.24	Interior speed 2	For JOG and speed mode	0~±6000 r/min	100
Pa.25	Interior speed 3	For JOG and speed mode	0~±6000 r/min P7=11 0~±32000	200

Pa.26	Interior speed 4	For JOG and speed mode	0~ ±6000 r/min P7=11 0~ ±32000	500
Pa.27	Highest rotate speed	Set motor highest rotate speed	0~6000 r/min	3600
Pa.28	Speed control zero difference compensation	Speed control compensates analog input . positive compensates if it is smaller than 10000;negative e compensates if it is bigger than 10000	0~ ±4000	0
Pa.29	Power proportion gain	As this is bigger , response is more rapid , and easy to produce vibration	1~1000	300
Pa.30	Servo INTH	0: Enable 1 : Disable , won't check INTH signal input 2 : Enable and Clear remain pulse	0~2	0
Pa.31	Servo alarm percent	Servo alarm PER0-10	1~300%	200
Pa.32	Highest motor current	Set motor highest current	1~800 x0.1A	100
Pa.33	Highest motor torque	Set motor highest torque	1~800 x0.1Nm	100
Pa.34	Motor zero offset pulse	Motor encoder zero varies from factory to factory, set it to make sure the current of the motor positive and negative rotate is same	1~ 10000 /Pa.35	2360
Pa.35	Servo motor's pole number	Please look the motor manual book	2~5	4
Pa.36	Position control's acceleration time	As this is bigger , Position response is more rapid and acceleration is bigger	0~ 30000	1000

Pa.37	Position control's reduce time	As this is bigger , Position response is more rapid and reduce is bigger	0~ 30000	1000
Pa.38	Speed control's accelerate time	As this is bigger , speed response is more rapid and acceleration is bigger	0~ 32000 P7=11 0~ ±32000	30
Pa.39	Speed control's reduce time	As this is bigger , speed response is more rapid and reduce is bigger	0~ 32000 P7=11 0~ ±32000	30
Pa.40	Inner pulse1	First segmeng pulse line	0~ ±32000	10000
Pa.41	Inner pulse2	Second segmeng pulse line	0~ ±32000	10000
Pa.42	Inner pulse3	Third segmeng pulse line	0~ ±32000	10000
Pa.43	Inner pulse4	Fourth segmeng pulse line	1~ ±32000	30000
Pa.44	Speed examines lowpass	① The lower parameter value and cut-off frequency are, the lower motor noise is. ② Should minish this parameter value as load is high ③ Speed response is more rapid , as this parameter value is getting bigger	1~300	36
Pa.45	Null			
Pa.46	Inner time1	First segmeng time	0~ 32000ms P7=11 0~ ±32000	500
Pa.47	Inner time 2	Second segmeng time	0~ 32000ms P7=11 0~ ±32000	500

Pa.48	Inner time 3	Third segmeng time	0~ 32000ms P7=11 0~ ±32000	500
Pa.49	Inner time 4	Fourth segmeng time	0~ 32000ms P7=11 0~ ±32000	500
Pa.50	Power control percent	Output coin signal when this power percent	0~100%	100
Pa.51	Check encode signal	0: Enable 1 : Disable , don't check encode signal input	0~1	0
Pa.52	History alarm record	1~10: Display History alarm record	0~10	0
Pa.53	Power on time	On brake delay time	0~ 30000ms	300
Pa.54	Power off time	Off brake delay time	0~ 30000ms	300
Pa.55	null			
Pa.56	Position order Pulse numerator 2	Same as Pa.12; En control channel-1; INTH control channel-2	1~ 30000	1

## 2.2 Note:

1. Must be sure to forbid the motor's running as setting or changing parameter
2. The motor's electrical wire must come away when changing the parameter Pa.35
3. Parameter Pa.11 must be reasonably used with parameter Pa.12、 Pa.13、 Pa.56
4. All parameter's setting only need SZGH- press "Enter" and needn't reboot, but must operate parameter read-in when save the parameter forever is needed.
5. Must wait for over 5 second after cut-off the driver's electricity



## Chapter 3 How to set servo System's parameter

### 3.1 Servo system display face

Servo system has six LED number display pipes and four keys on the board. Number display pipes are used for displaying servo System's all kinSZGH- of status and parameters; Key is used for reading and setting System parameter.

Servo System commonly has five display modes as follow:

- 1) Rotation speed mode:  
parameter P0.3=0 unit: r/min



- 2) Current mode :  
parameter P0.3=1 unit: A



- 3) Torque mode:  
parameter P0.3=2 unit: NM



- 4) Motor position mode:  
parameter P0.3=3 unit: pulse



- 5) Position error:  
parameter P0.3=4 unit: pulse



- 6) Low four bits of input

pluse:  
parameter P0.3=5 unit: pulse



7) High four bits of input pluse:  
parameter P0.3=6 unit: pulse



### 3.2 Set servo System parameter

Under the normal display mode: press “←”key to operate “setting parameter”、 “write-in parameter”、 “initialize parameter”。

Note: If not input System password you only enter “setting parameter”, moreover , only read parameter、 input password and change parameter P0.3, cannot change other parameter。

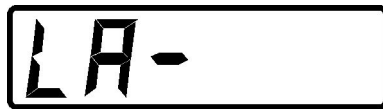

When display “write-in parameter”、 “initialize parameter”, press key of“↑” to return the status of System boot-strap。

#### 3.2.1 Set parameter

- Select parameter number: If press key of “↑”, then increase parameter number; If press key of “↓”, then decrease parameter number。
- Press key of“Enter”, enter the status of changing parameter。 On this time, System will open content of all selected parameter in order to read and change。

- Press key of “←”: enter the status of write-in parameter.  
Note: when open parameter P0.1, only display “0”, not display system password.



- 1) Press “↑”key, current number add 1 (Current number is the currently displayed figure) .



- 2) Press “←”key, current number move forward.



- 3) Press “↓”key, current number reduce 1.



- 4) Press “Enter”key, confirm the number inputed and return. If not input System password, the input number is disable and return to the status of boot-strap.



- 5) Input and change the password  
On each boot and set parameter, system password must be input at first, the parameter P0.1 is the password. When correctly input password, we can set other parameter, otherwise we cannot change it.

If want to change password we must firstly input old password, then set parameter P0.1. If user forget System password, please contact with us.

### 3.2.2 Write-in parameter

A rectangular LCD display showing the characters 'EE-' in a bold, monospaced font.

On this time, press “←”key: enter the status of initializing parameter.

As users need to save revised parameter for long time, he must operate write-in parameter. Press and hold“Enter”for about three seconSZGH-, the parameter will be written in the interior EEPROM. Write-in processes as follow:

A rectangular LCD display showing the characters 'EE--' in a bold, monospaced font.

A rectangular LCD display showing the characters 'EE---' in a bold, monospaced font.

A rectangular LCD display showing the characters 'EE----' in a bold, monospaced font.

A rectangular LCD display showing the characters 'Flash' in a bold, monospaced font.

On this time, press“Enter”key to return.

### 3.2.3 Initialize parameter

A rectangular LCD display showing the characters 'LA-' in a bold, monospaced font.

On this time, press “←”key: enter the status of setting parameter.

When user need to set the parameter to be leave-factory value, press“Enter”key for three seconSZGH-, All parameter except password will be initialized by leave-factory value, but the leave-factory value won't write in interior EEPROM.

Displaying processes follow:

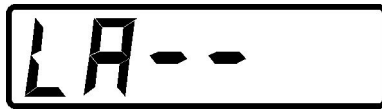
A rectangular LCD display showing the characters 'LA' followed by two dashes.A rectangular LCD display showing the characters 'LA' followed by three dashes.A rectangular LCD display showing the characters 'LA' followed by four dashes.A rectangular LCD display showing the characters 'Fl nSh'.

On this time, press“Enter”to return。

### **3.3 Servo System’s JOG control**

When System parameter Pa.7 equals to 1, servo System is JOG control mode。

Press and hold“↑”to make servo motor positive rotation, loosen key to stop motor rotation。Rotation speed is determined by the parameter Pa.21。

Press and hold“↓”to make servo motor minus rotation, loosen key to stop motor rotation。Rotation speed is determined by the parameter Pa.21。

### **3.4 Servo System’s position control**

When system parameter Pa.7 is 0 , or Pa.7 is 4 and EN(channel-1),INTH(channel-2) is disable, the servo System is in position control mode。Rotation speed is determined by CP frequency, direction by DIR。INTH and Pa.30 may forbid this function。

### **3.5 Servo System’s speed control**

When System parameter Pa.7 is 2 , or Pa.7 is 4 and and EN(channel-1),INTH(channel-2) is enable, servo System is in speed control mode。The maximum rotation speed is determined by the parameter Pa.22。Rotation speed is determined by the voltage of Vin, direction by the sign of Vin。

### 3.6 Inner pulse control

When System parameter Pa.7 is 5 ,may startup inner pulse,Pa.40,41,42,43 are executed one by one with speed of Pa.23,24,25,26 and direction of Pa.45. the speed must be less then  $60 \cdot Pa.12 / Pa.13$  .

The dwell time of between segments is Pa.46,Pa.47,Pa.48,Pa.49.

## Chapter 4 servo system's maintenance

Errors alarm list:

Alarm code	Alarm content	Alarm cause	Solution
ERa-1 (a=1 or 2)	Motor speed rotates too high	① Rotation speed too high ② Parameter Pa.27 too small	① Reduce rotation speed ② Change Pa.27
ER0-3	Power error	① Servo system doesn't connect with power ② Insurance ruins	① Connect with servo main power ② Replace insurance ③ Replace bad pieces
ERa-4	Position error too big	① Machine is block ② Parameter Pa.17 too big ③ Parameter Pa.18 too small ④ Parameter Pa.27 too small ⑤ Input pulse frequency too high	① Examine machine ② Change correspond parameter ③ Induce rotation speed
ERa-6	Memory error	U19 are bad	Replace bad pieces
ERa-9	Encode trouble	① Encode signal error ② Encode wire ruins or shield isn't good	① Replace encode or wire ② Set Pa.51=1
ERa-10	Motor Power is too	① Motor and down-lead wire are short or motor	① Replace motor ② Change Pa.31

	big	insulation breaks down ② Parameter Pa.31 is too small	
ERa-11	IPM module trouble	① IPM module ruins ② Temperatuer is too high ③ Voltage is too high ④ Motor insulation ruins	① Replace IPM module ② Replace motor ③ Check power
ERa-12	Motor current is too big	③ Motor and down-lead wire are short or motor insulation breaks down ④ Parameter Pa.8 is too small ⑤ IPM module is bad	③ Replace motor ④ Replace IPM module ⑤ Change Pa.8
Others	Don't display	Cutting off and booting's interval is too short	Wait for one minute, then operate

As servo System produce alarm, don't boot before clear up the alarm cause, otherwise, it is easy to ruin servo System. When need debug System as servo System doesn't connect with servo main power and servo System produces alarm Pa.8, may press "Enter" key to enter servo debug System.

# Appendix

## Wiring:

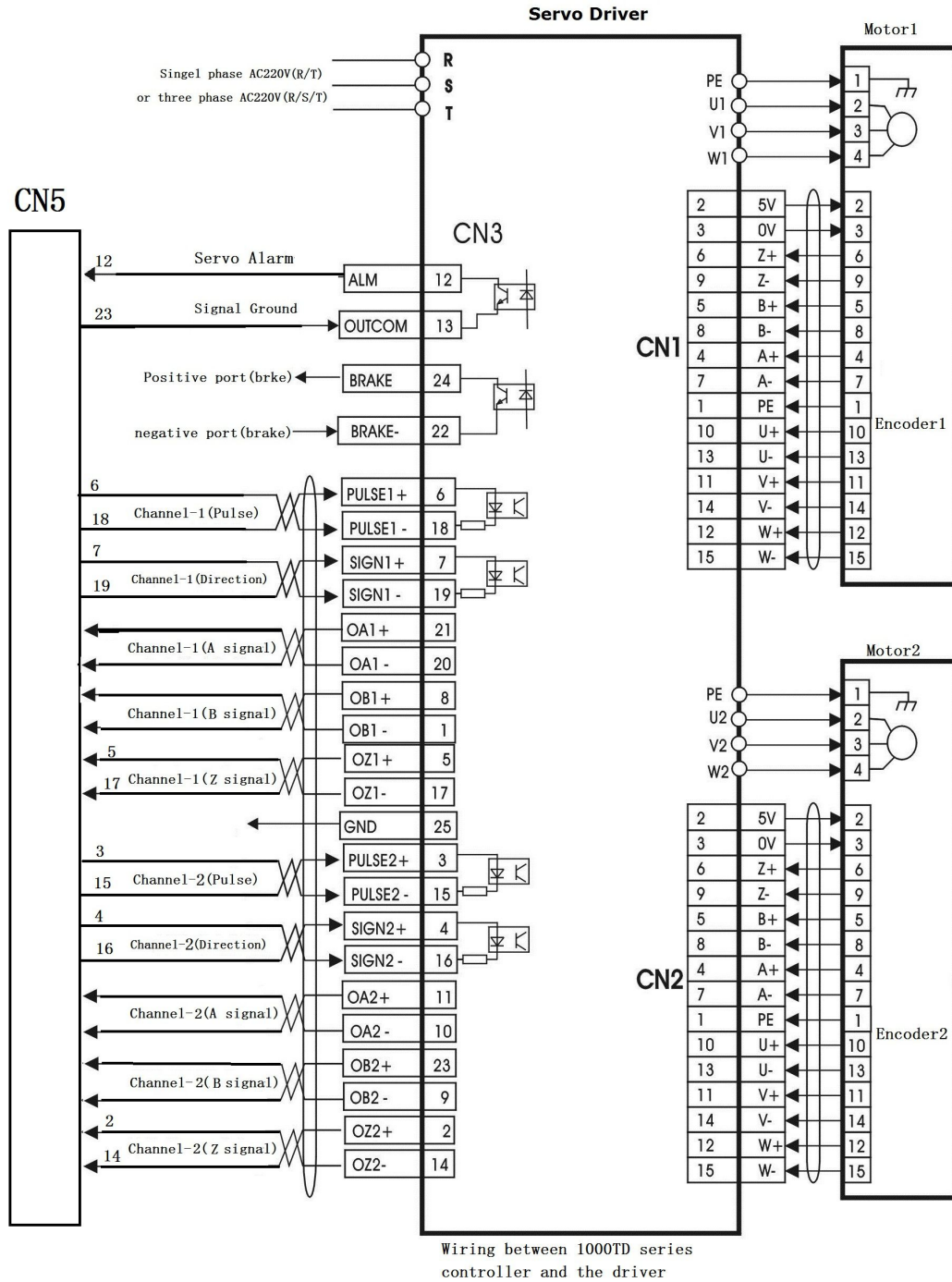

**Note: this is the wiring between SZGH-CNC1000TDb/c series controller and the driver(302). channel-1 is for X-axis control signal, channel-2 is for Z-axis control signal.**



## **Системы ЧПУ:**

SZGH-CNC1000MDi & CNC1000TDi

SZGH -GH1000MC

SZGH -GH1000TC

SZGH-CNC990MDb-3/4

SZGH-CNC990MDc-3

SZGH-CNC1000MDb-3/4/5

SZGH-CNC1000MDc-3

SZGH-CNC1000GDb-2/3/4/5

SZGH-CNC1000TDc-2/3/4/5

## **Шпиндельные приводы и серводрайверы:**

SZGH08-3-9.5-1.5/2.2-4-1500 - SZGH-S4T1P5

SZGH08-4-14-2.2/3.7-4-1500 - SZGH-S4T2P2

SZGH09-2-24-3.7/5.5-4-1500 - SZGH-S4T5P5

SZGH10-2-35-5.5/7.5-4-1500 - SZGH-S4T7P5

SZGH10-3-48-7.5/11-4-1500 - SZGH-S4T011

SZGH10-4-71-11/15-4-1500 - SZGH-S4T015

SZGH13-2-95-15/18.5-4-1500 - SZGH-S4T018

SZGH13-3-117-18.5/22-4-1500 - SZGH-S4T022

SZGH13-4-140-22/30-4-1500 - SZGH-S4T030

SZGH16-1-191-30/37-4-1500 - SZGH-S4T037

SZGH16-2-235-37/45-4-1500 - SZGH-S4T045

SZGH16-3-286-45/55-4-1500 - SZGH-S4T055

SZGH16-4-350-55/75-4-1500 - SZGH-S4T075

SZGH18-1-478-75/90-4-1500 - SZGH-S4T090

SZGH18-2-573-90/110-4-1500 - SZGH-S4T110

SZGH18-3-700-110/132-4-1500 - SZGH-S4T132

SZGH22-1-840-132/160-4-1500 - SZGH-S4T090